

Washington County Secondary Roads Application for Access

Landowner Name _____ Date _____
Address _____ Phone _____

Location of Access

Road Name: _____ Access into: (circle one)
Township _____ Sec _____ Qtr _____ Field Home Business
Description of work to be completed:

I have read Washington County's policy on entrances onto County Roads and am hereby requesting authorization from Washington County to construct or widen an access driveway at the above location.

Applicant Signature

Summary of Washington County's Policy on Entrances (For further details, see Section 14.09 in the Washington County Code of Ordinances)

1. The property owner or tenant is responsible for installation and providing all materials for the initial entrance construction or modification of existing driveways.
2. The access location must provide adequate sight distance and must meet the entrance specifications provided on the attached detail sheet.
3. The County Engineer will determine the required pipe diameter if required. Culvert pipe must be corrugated metal, tied reinforced concrete, PVC plastic, or High Q plastic pipe. After installation, the culvert pipe shall become the property of Washington County.
4. Entrances shall be constructed using compaction, shall not interfere with the traveled roadway, and shall be guaranteed by the applicant for three (3) years.
5. The County Engineer shall approve the completed installation before accepting it.
6. Washington County will maintain any entrance within the right-of-way that has been installed with an approved permit and constructed according to County specification.
7. Washington County does not furnish, maintain, nor pay for any driveway surfacing for roadway accesses.

For County Use:

Pipe Size & Length _____ Approved/Denied on (date) _____
Sight Distance _____ Reviewed by _____

Notes _____

WASHINGTON COUNTY ENTRANCE DETAIL SHEET

CENTERLINE OF COUNTY ROAD
(GRAVEL OR PAVED)



PLAN VIEW

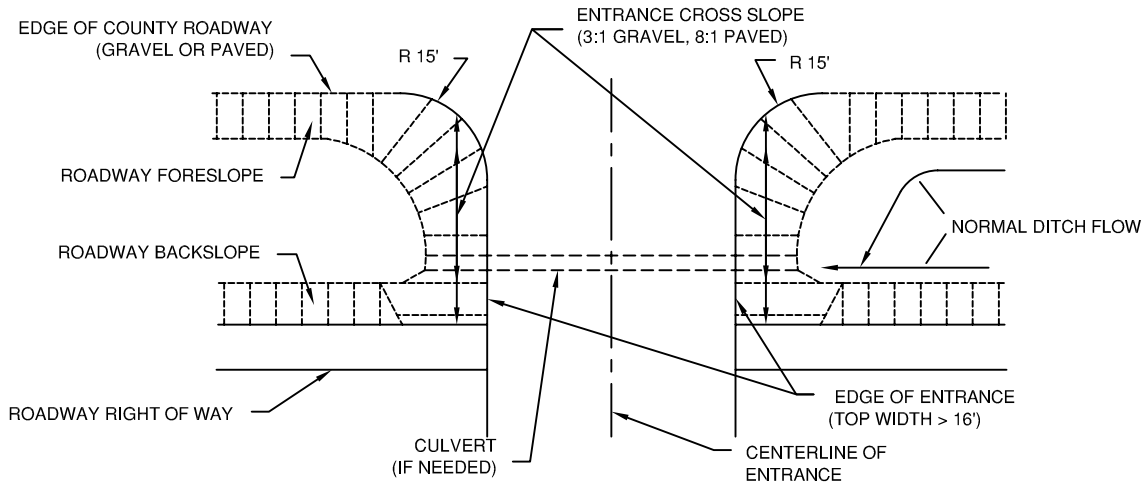

PROFILE VIEW

NOTE:
THE FINISHED SURFACE
ELEVATION OF A ROADWAY
ACCESS SHALL BE INITIALLY
SLOPED AT 4% AWAY FROM THE
ROAD

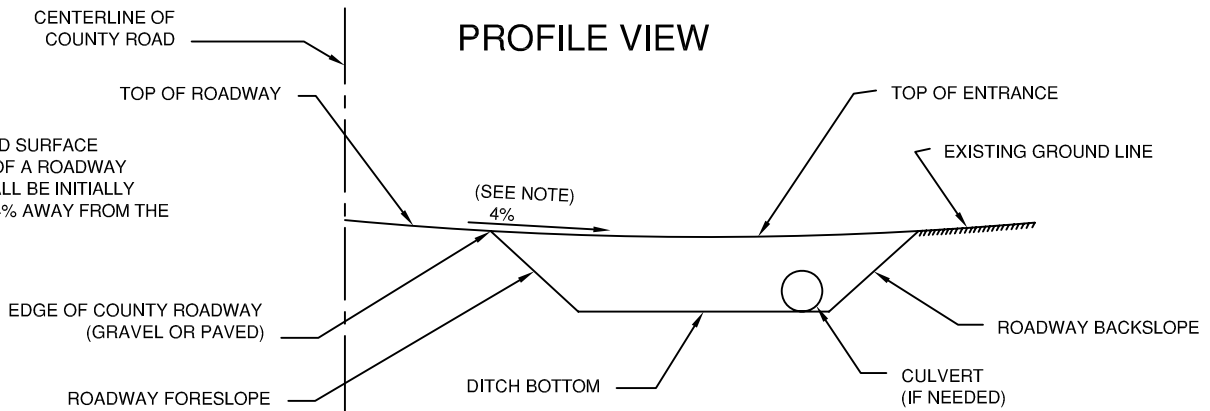

CROSS SECTION VIEW

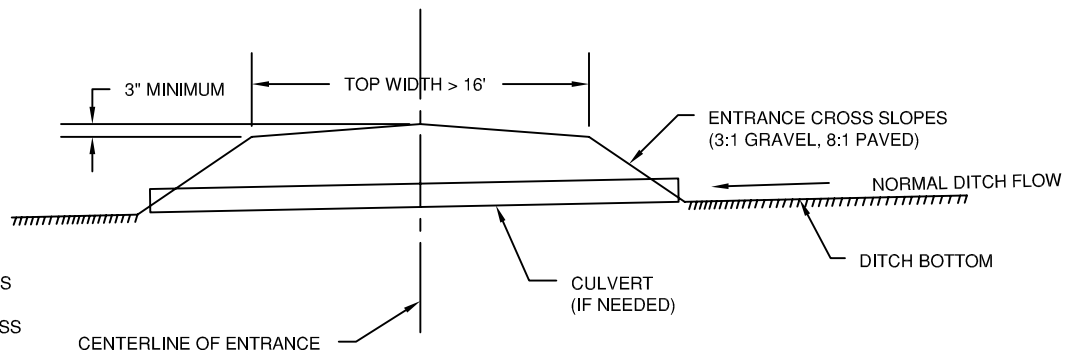

GENERAL NOTES:
ENTRANCES THAT DO NOT
REQUIRE CULVERTS SHALL BE
CONSTRUCTED WITH 3:1 CROSS
SLOPES (GRAVEL), AND 10:1
CROSS SLOPES (PAVED). CROSS
SLOPES ARE SHOWN AS
HORIZONTAL OVER VERTICAL.